

Terreinoverzicht Horst 2014

- Km 1: in H1
- Km 2: voor H2
- Km 3: in H3
- Km 4: na H4
- Km 5: voor H5
- Km 6: in H6
- Km 7: in H7

B-traject: 7500 m

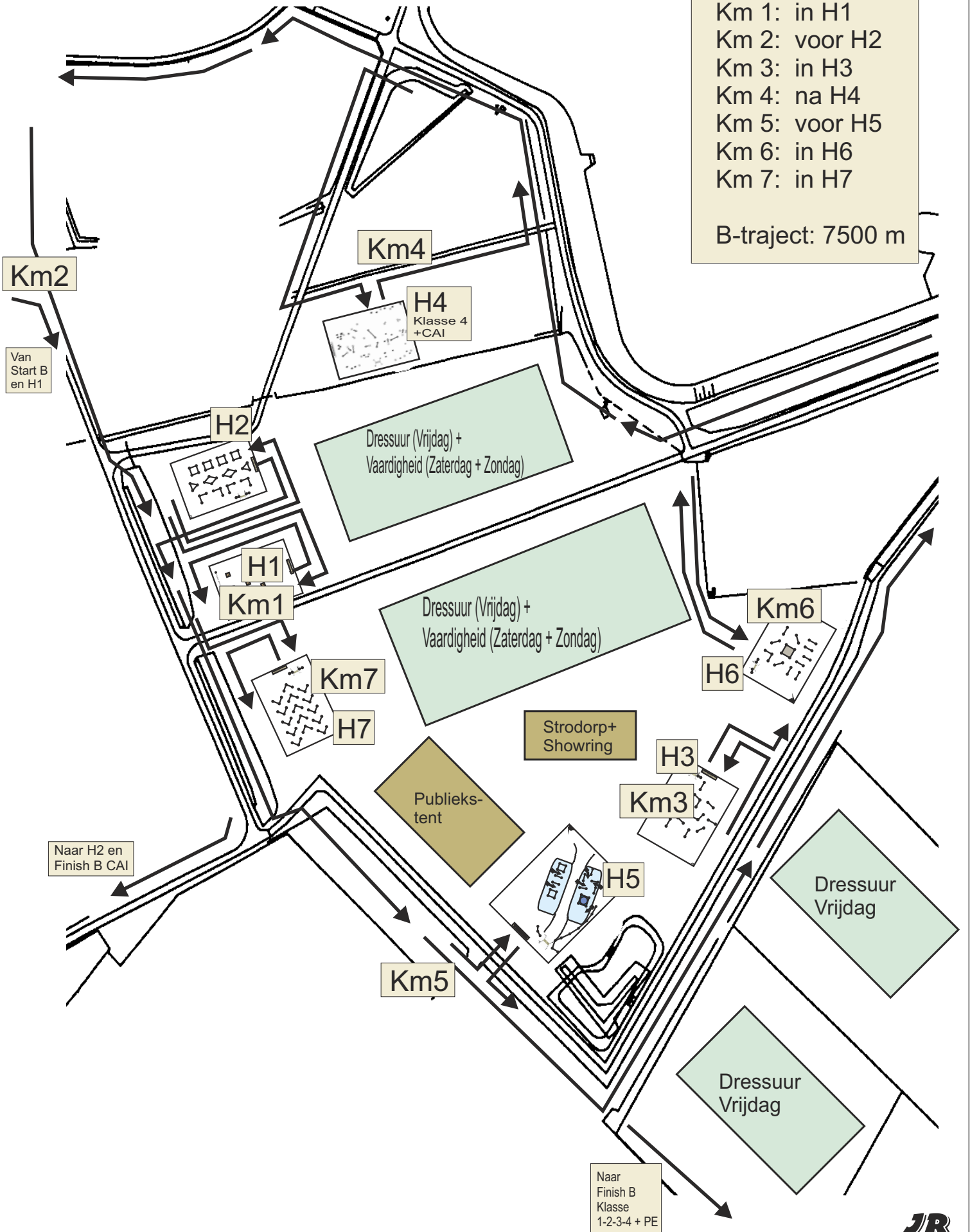

Competition grounds Horst 2014

Km 1: in H1
 Km 2: before H2
 Km 3: in H3
 Km 4: after H4
 Km 5: before H5
 Km 6: in H6
 Km 7: in H7

 B-section: 7500 m

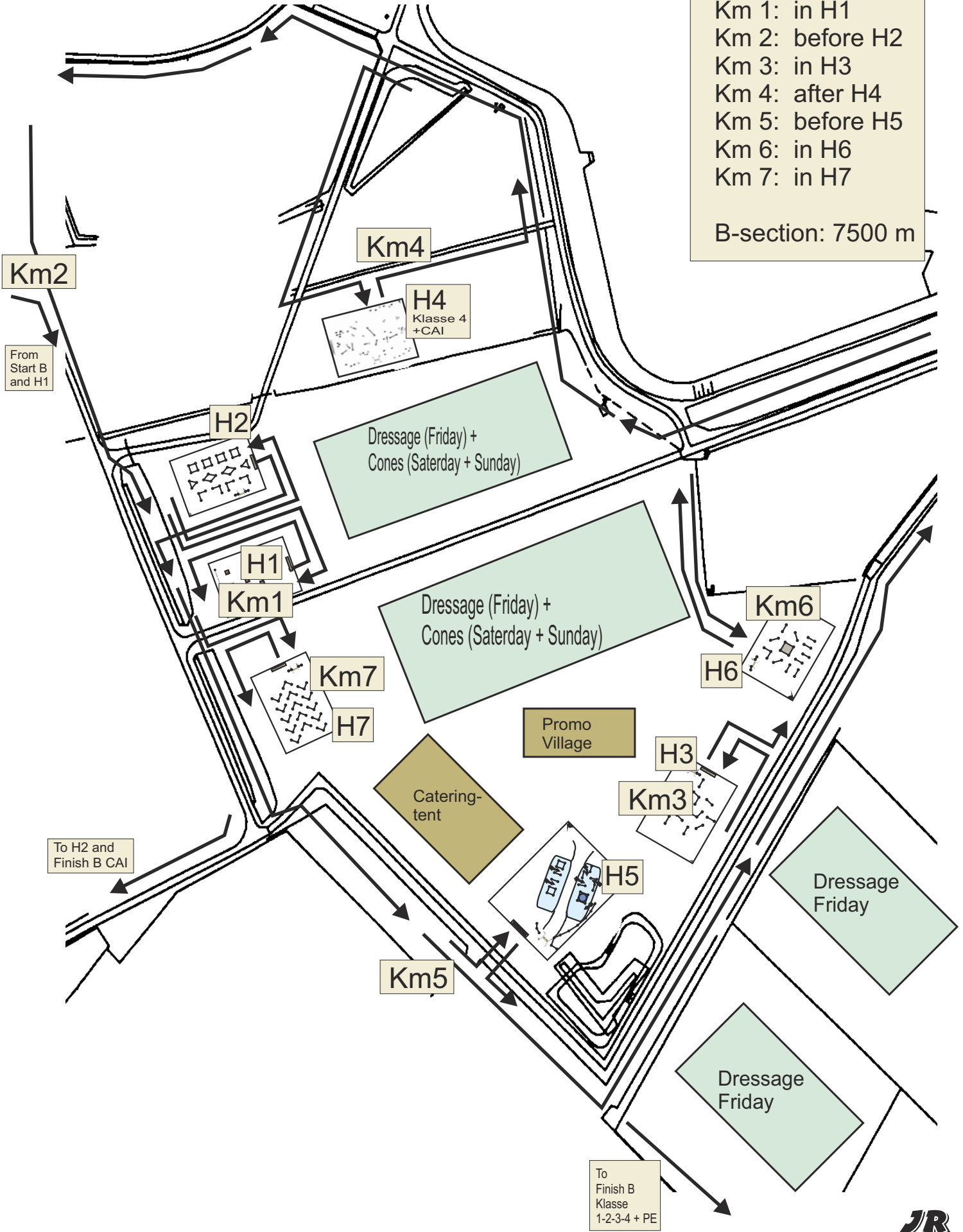

Trajecten / Sections Marathon Horst 2014

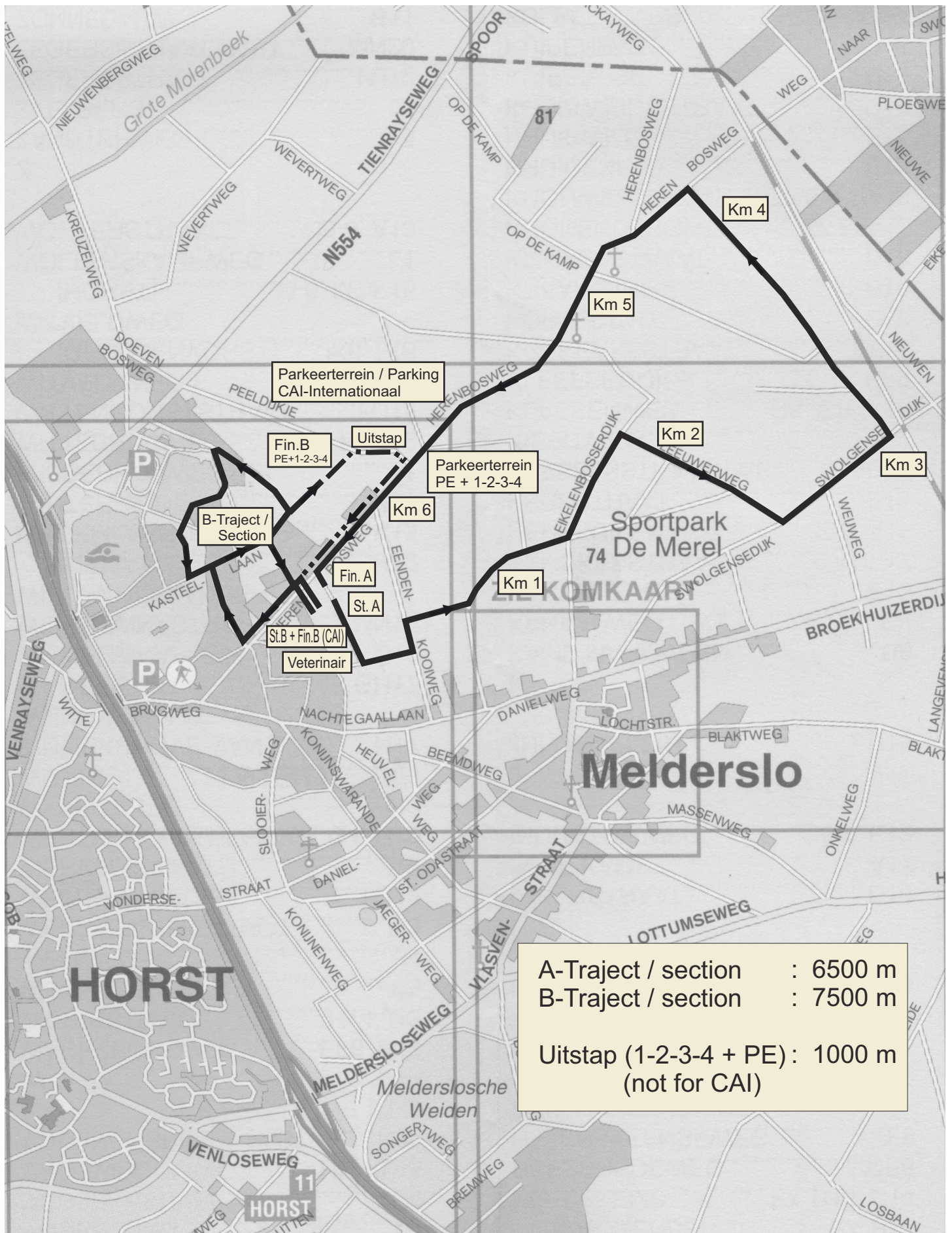

A-Traject / section : 6500 m
 B-Traject / section : 7500 m
 Uitstap (1-2-3-4 + PE) : 1000 m
 (not for CAI)

Hindernis / Obstacle 1.

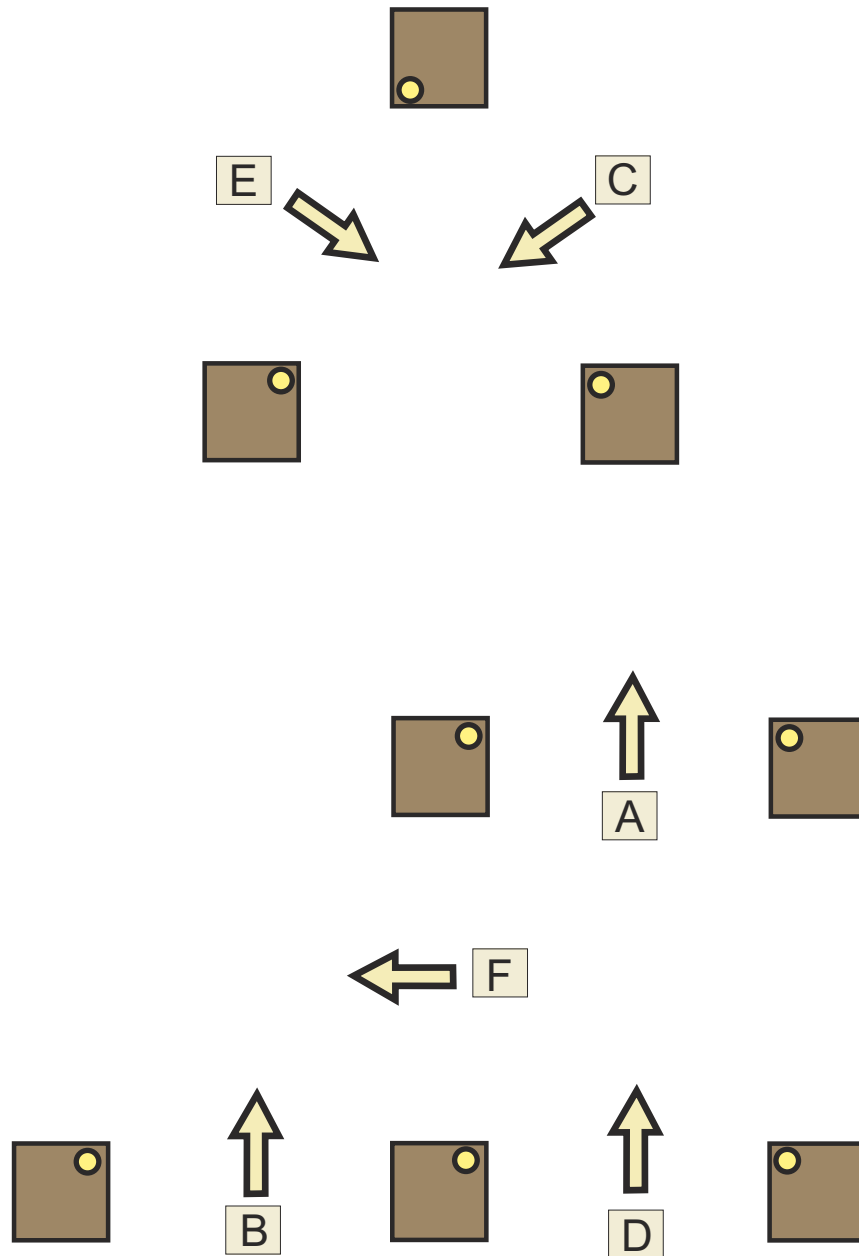
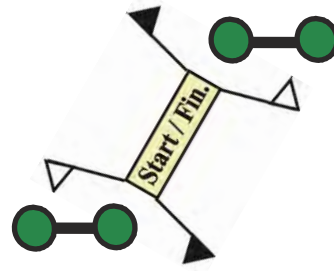

● = Afrijdbaar element / Knock down

Hindernis / Obstacle 2.

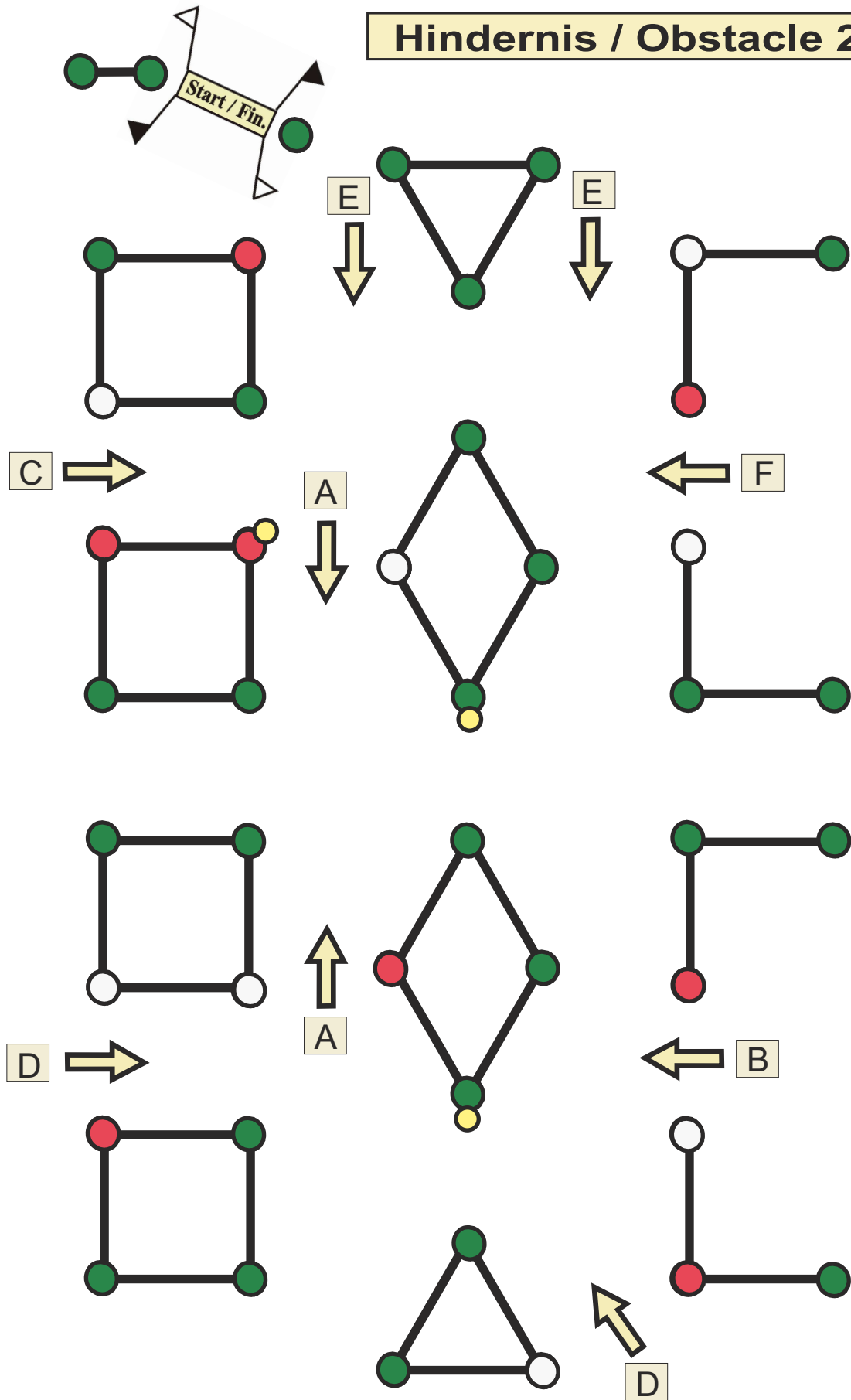

Hindernis / Obstacle 3.

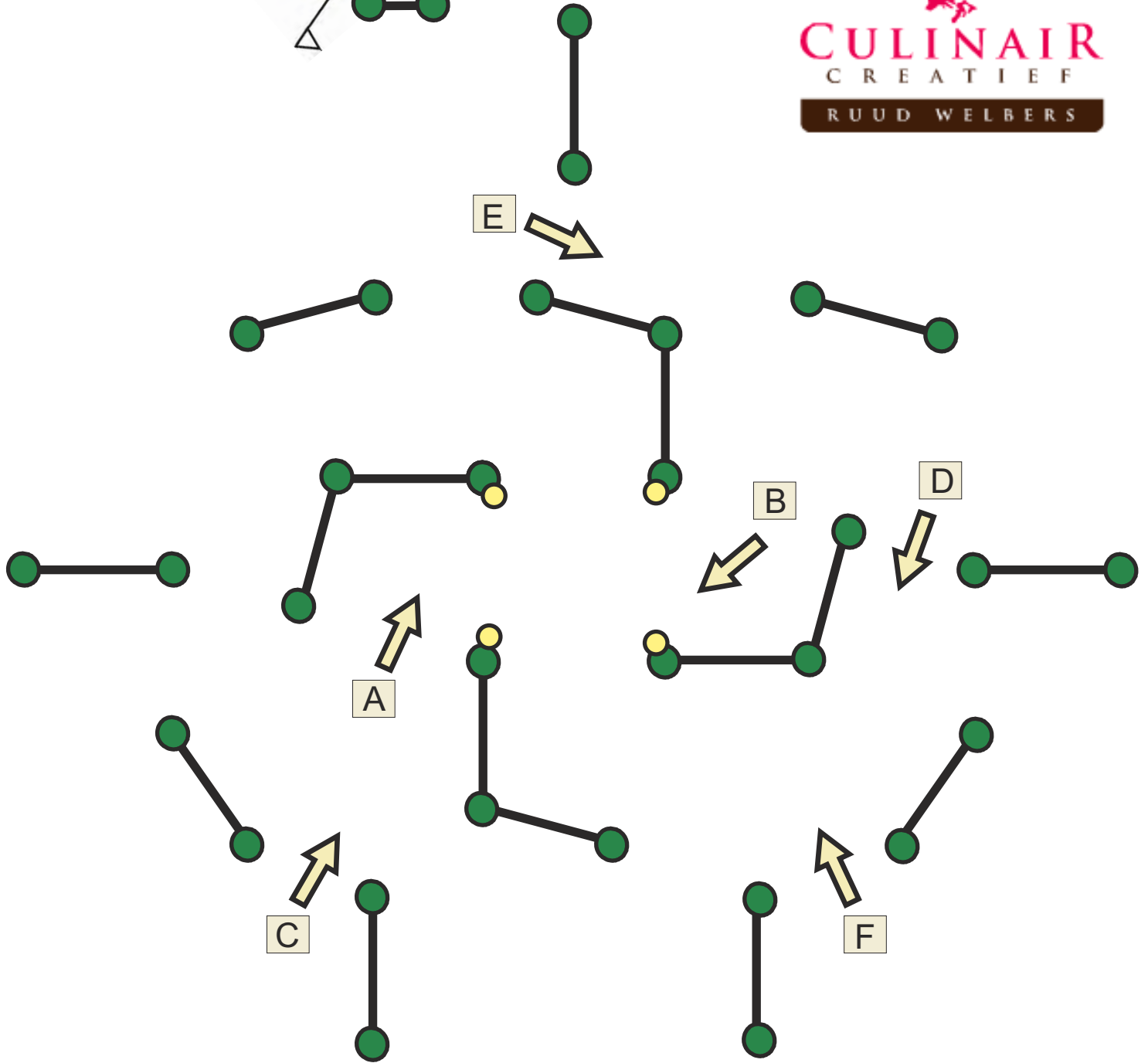
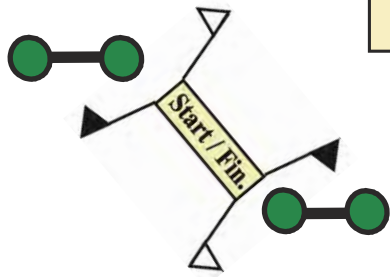

● = Afrijdbaar element / Knock down

Hindernis / Obstacle 4.



Menwedstrijden

Horst a/d Maas

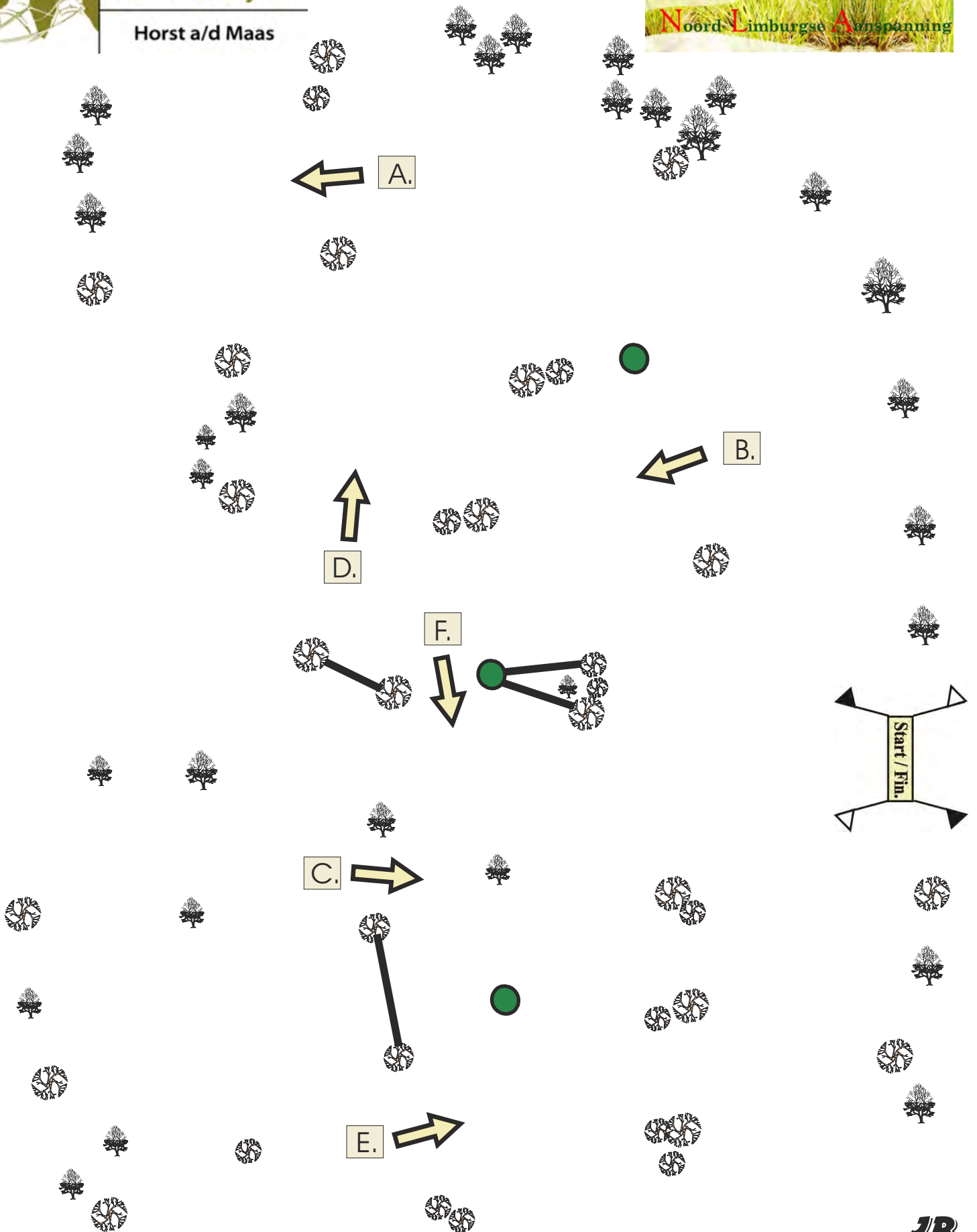

Hindernis / Obstacle 5.

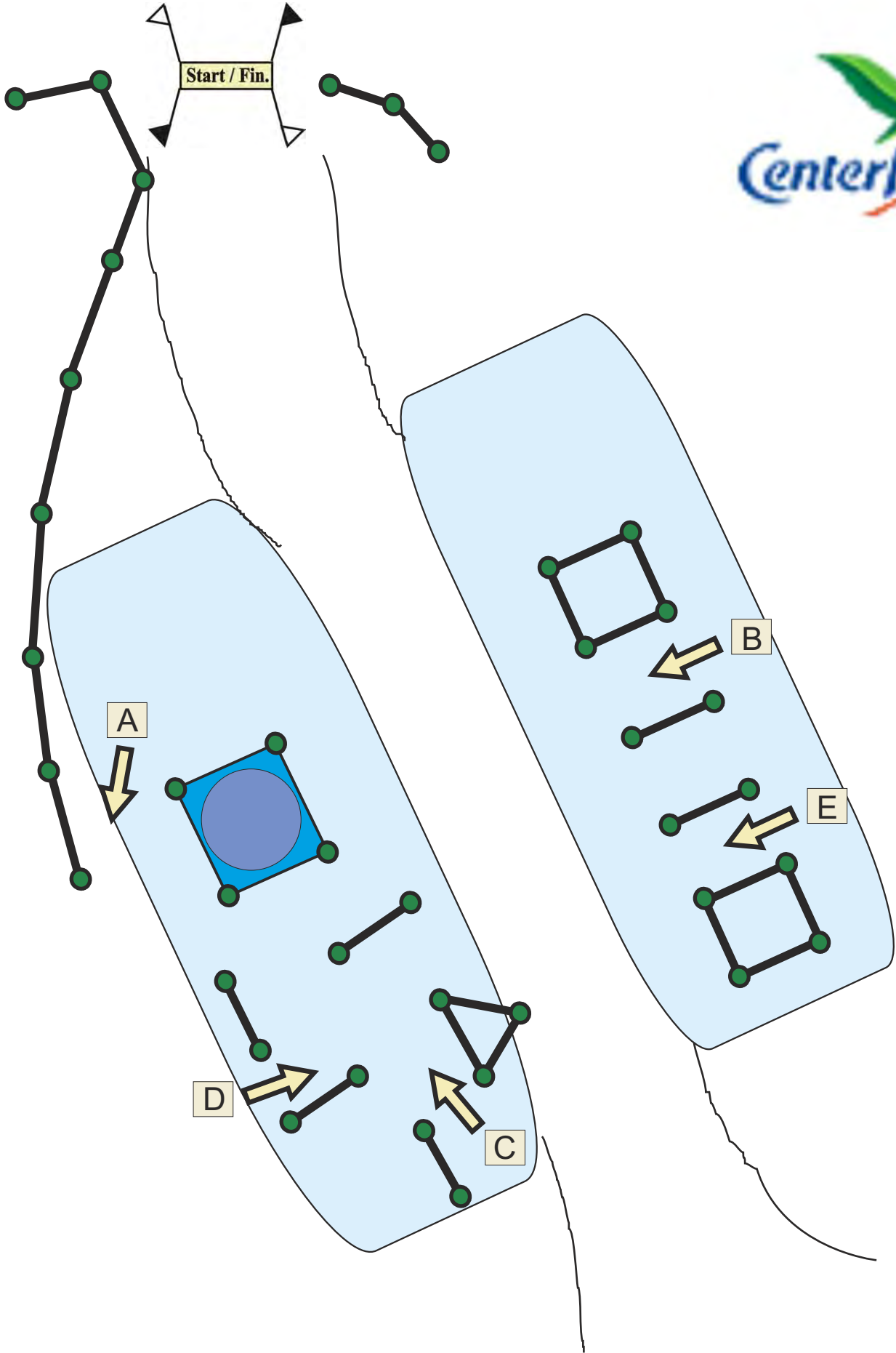

Hindernis / Obstacle 6.



Rabobank

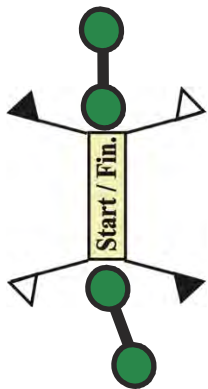
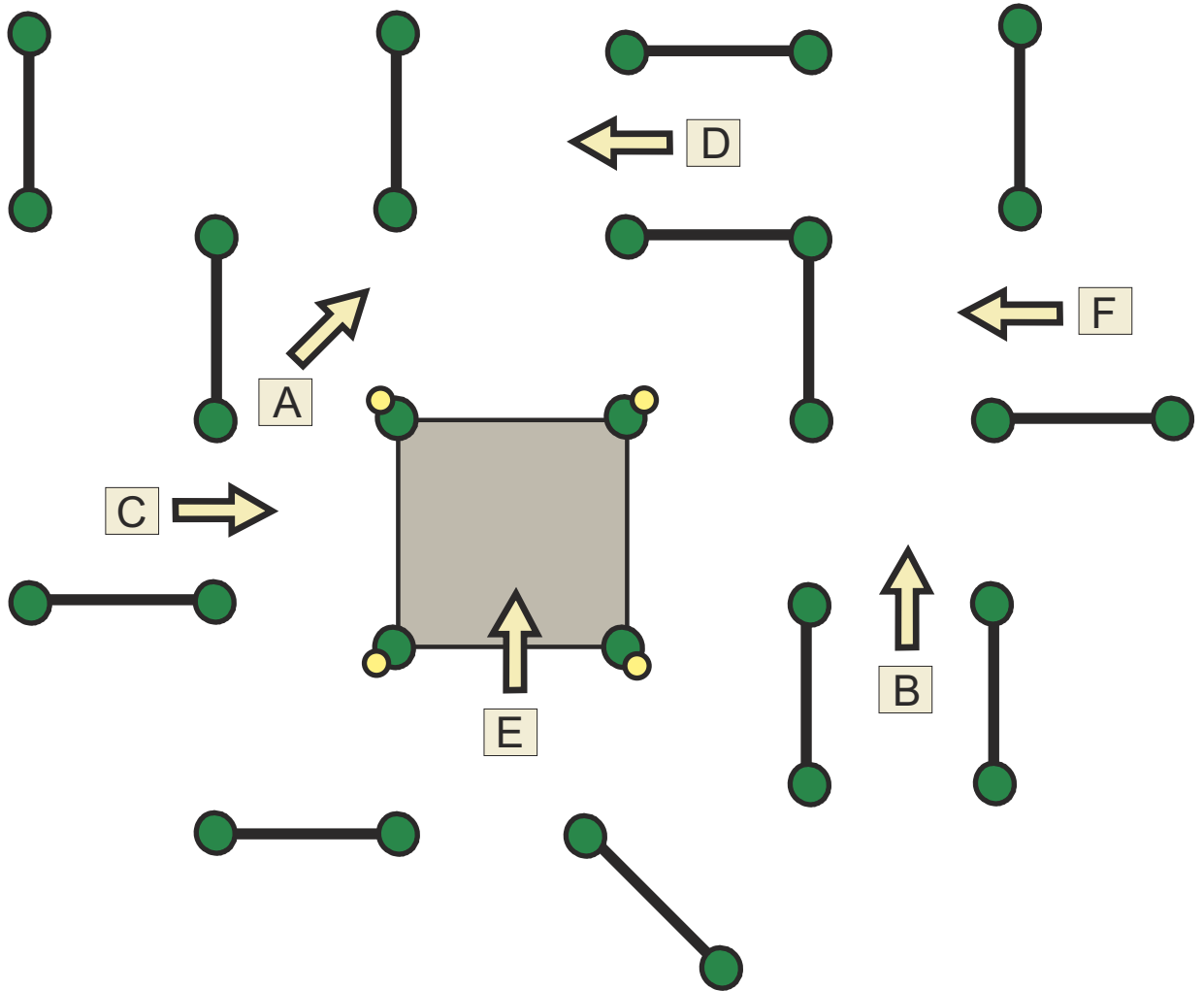

● = Afrijdbaar element / Knock down



Hindernis / Obstacle 7.

GO FOR GOLD
haal het beste uit jezelf



gemeente

HORST
A/D
MAAS

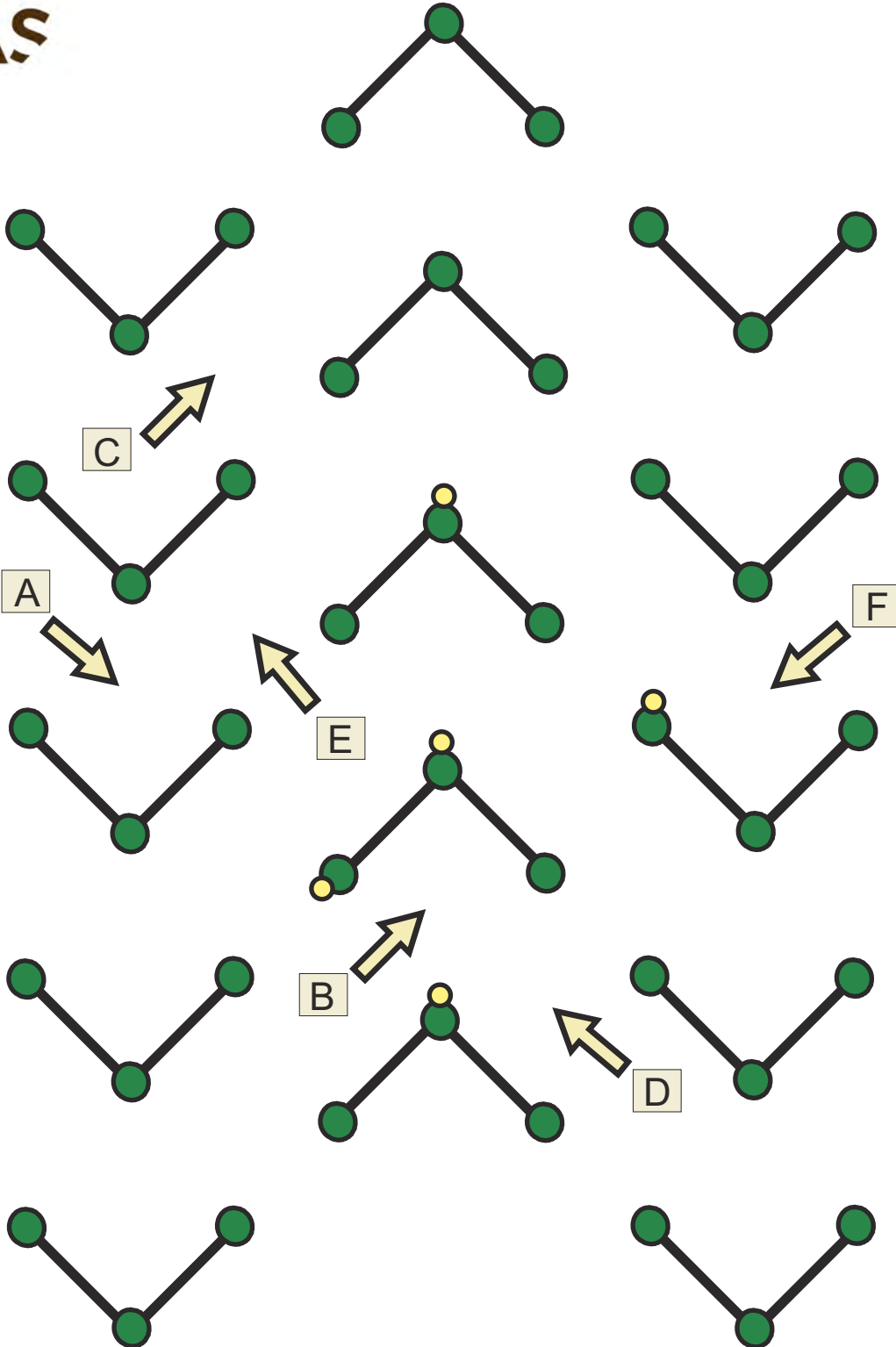
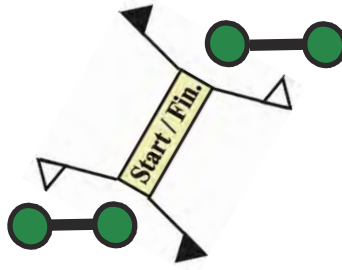

● = Afrijdbaar element / Knock down

S.W.M. te Horst op 24 t/m 27 april 2014							
MARATHON OVERZICHT			Pony Klasse 3				
	Lengte in meters	Voorgeschreven gang	Snelheid in km/u	Minimum tijd	Toegestane tijd	Maximum tijd	Verplichte doorgang
A-Traject	6.500	vrij	11	0:33:28	0:35:28	0:42:34	0
Neutrale zone 1	50				0:02:00		
Verplichte rust					0:10:00		
Neutrale zone 2	50				0:02:00		
B -Traject	7.500	reglement	12	0:34:30	0:37:30	1:15:00	0
Uitstaptraject	1.000	reglement			0:15:00		
Totaal	15.100				1:41:58		0

S.W.M. te Horst op 24 t/m 27 april 2014							
MARATHON OVERZICHT			Paard Klasse 3				
	Lengte in meters	Voorgeschreven gang	Snelheid in km/u	Minimum tijd	Toegestane tijd	Maximum tijd	Verplichte doorgang
A-Traject	6.500	vrij	12	0:30:30	0:32:30	0:39:00	0
Neutrale zone 1	50				0:02:00		
Verplichte rust					0:10:00		
Neutrale zone 2	50				0:02:00		
B -Traject	7.500	reglement	13	0:31:37	0:34:37	1:09:14	0
Uitstaptraject	1.000	reglement			0:15:00		
Totaal	15.100				1:36:07		0

S.W.M. te Horst op 24 t/m 27 april 2014							
MARATHON OVERZICHT			Pony Klasse 4				
	Lengte in meters	Voorgeschreven gang	Snelheid in km/u	Minimum tijd	Toegestane tijd	Maximum tijd	Verplichte doorgang
A-Traject	6.500	vrij	12	0:30:30	0:32:30	0:39:00	0
Neutrale zone 1	50				0:02:00		
Verplichte rust					0:10:00		
Neutrale zone 2	50				0:02:00		
B -Traject	7.500	reglement	13	0:31:37	0:34:37	1:09:14	0
Uitstaptraject	1.000	reglement			0:15:00		
Totaal	15.100				1:36:07		0

S.W.M. te Horst op 24 t/m 27 april 2014							
MARATHON OVERZICHT			Paard Klasse 4				
	Lengte in meters	Voorgeschreven gang	Snelheid in km/u	Minimum tijd	Toegestane tijd	Maximum tijd	Verplichte doorgang
A-Traject	6.500	vrij	13	0:28:00	0:30:00	0:36:00	0
Neutrale zone 1	50				0:02:00		
Verplichte rust					0:10:00		
Neutrale zone 2	50				0:02:00		
B -Traject	7.500	reglement	14	0:29:09	0:32:09	1:04:18	0
Uitstaptraject	1.000	reglement			0:15:00		
Totaal	15.100				1:31:09		0

CAI-H4, CAI-H2, CAI H1 Horst 26-27 April 2014

<i>MARATHON TIMETABLE</i>			<i>HORSES</i>				
	length	pace	speed in km/h	Minimum time	Time allowed	Maximum time	Obligatory gates
Phase A	6.500	free	13	00:28:00	00:30:00	00:36:00	0
Neutral Zone	50				00:02:00		
Rest					00:10:00		
Neutral Zone	50				00:02:00		
Phase B	7.500	Acc. To rules	14	00:29:09	00:32:09	01:04:18	0
Total	14.100				01:31:09		0